

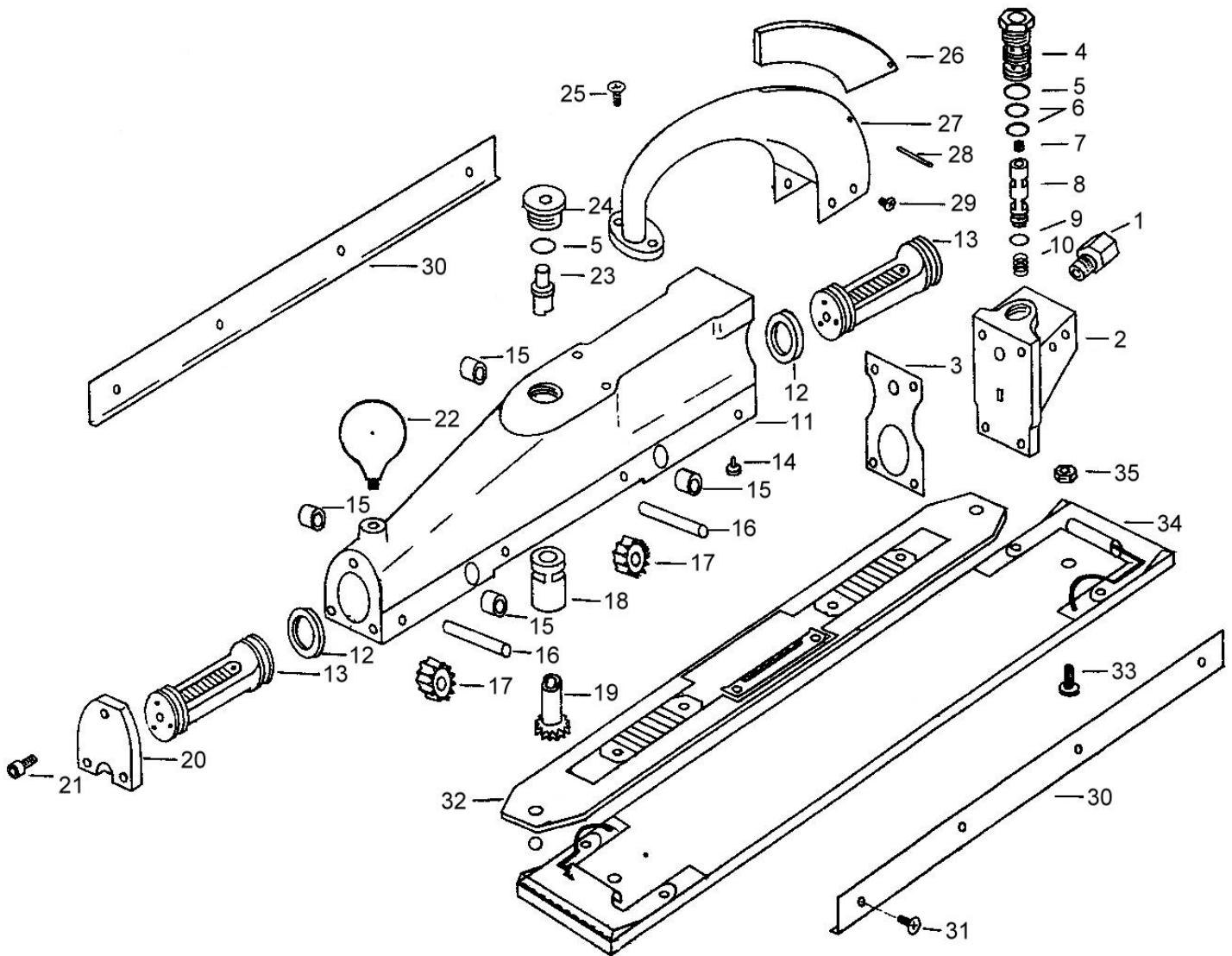

GISON Pneumatic Tools

GP-845A Straight Line Sander (dual Pis.)



PARTS LIST

✳ :Consuming Part

Item No.	Part No.	Description	Qty.	Item No.	Part No.	Description	Qty.
1	845A01	Hose Adapter	1	19	845A19	Actuator Gear	1
2	845A02	Rear Head	1	20	845A20	Front Head	1
3	845A03	Parking	1	21	845A21	Socket Cap Scr.	7
4	845A04	Valve	1	22	845A22	Knob Assembly	1
5	845A05	O-Ring	2	23	845A23	Adj. Shaft	1
6	845A06	O-Ring	2	24	845A24	Plunger	1
7	845A07	Socket Scr.	1	25	845A25	Philips Rd. Hd. Scr.	2
8	845A08	Switch Control Bat	1	26	845A26	Trigger	1
9	845A09	O-Ring	1	27	845A27	Handle	1
10	845A10	Spring	1	28	845A28	Roll Pin	1
11	845A11	Body Assembly	1	29	845A29	Flat Headle Scr.	4
12	845A12	Piston Ring	2	30	845A30	Side Strape	2
13	845A13	Piston	2	31	845A31	Philips Rd. Hd. Scr.	8
14	845A14	Wear Button	8	32	845A32	Carrier Assembly	1
15	845A15	Bearing	4	33	845A33	Philips Rd. Hd. Scr.	2
16	845A16	Shaft	2	34	845A34	Pad Assembly	1
17	845A17	Gear	2	35	845A35	Hex. Nut	2
18	845A18	Actuator Valve	1				