

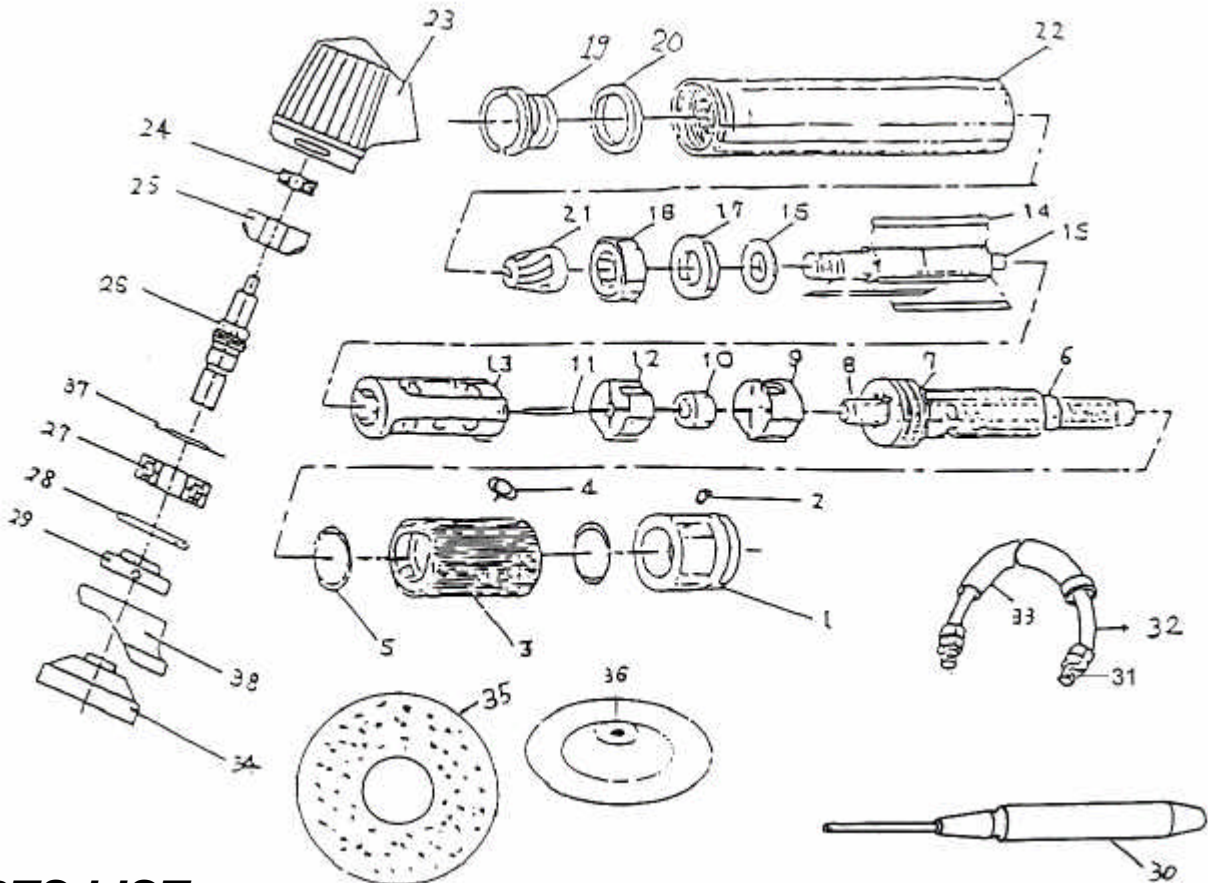

GISON Pneumatic Tools

GP-8241 Micro Air Grinder (22,000rpm)



PARTS LIST

✳ : Consuming Part

Item No.	Part No.	Description	Qty.	Item No.	Part No.	Description	Qty
1	824101	Rear End Holder	1	20	824120	Brass Spacer	1
2	824102	Screw	1	21	824121	Screw Gear	1
3	824103	Sliding Knob	1	22	824122	Sleeve	1
4	824104	O-Ring	1	23	824123	Bend Shell	1
5	824105	O-Ring	2	✳ 24	824124	Ball Bearing	1
6	824106	Hose Plug	1 Set	25	824125	Screw Gear	1
7	824107	Pin		26	824126	Driven Shaft	1
8	824108	Intake Stainless Steel Tube	1	✳ 27	824127	Ball Bearing	1
9	824109	Intake Plate		28	824128	Flange	1
✳ 10	824110	Ball Tearing	1	29	824129	Flange Nut	1
11	824111	Pin	1	30	824130	Lock Wrench	1
12	824112	Bearing Plate	1	31	824131	Connector	1
13	824113	Cylinder	1	32	824132	Inlet Hose	1
✳ 14	824114	Fiber Vanes	3	33	824133	Exhaust Hose	1
15	824115	Rotor	1	34	824134	Cup Wheel	1
16	824116	Spacer	1	35	824135	Abrasive Disc	9
17	824117	Lateral disc	1	36	824136	Rubber Wheel	1
✳ 18	824118	Ball Bearing	1	37	824137	Bearing Cap	1
19	824119	Brass Lock Screw	1	38	824138	Guard Cover	1

Application: Ideal for grinding metal model, machine processing, engrave wood, and parts processing.

Features:

- It can handle 1/8" and 3 mm capacity collet chuck.
- Easy-to-handle roll type throttle for instant adjustment of speed.
- Built-in silencer for quiet operation.
- Ultra precision bearings support the rotating parts for true running.
- Air motor for high speed operation less heating.
- Interchangeable with various heads for wide application.
- It has good motor at 20,000~22,000 RPM.