

GISON Pneumatic Tools

GP-T64 Heavy Duty T-nailer

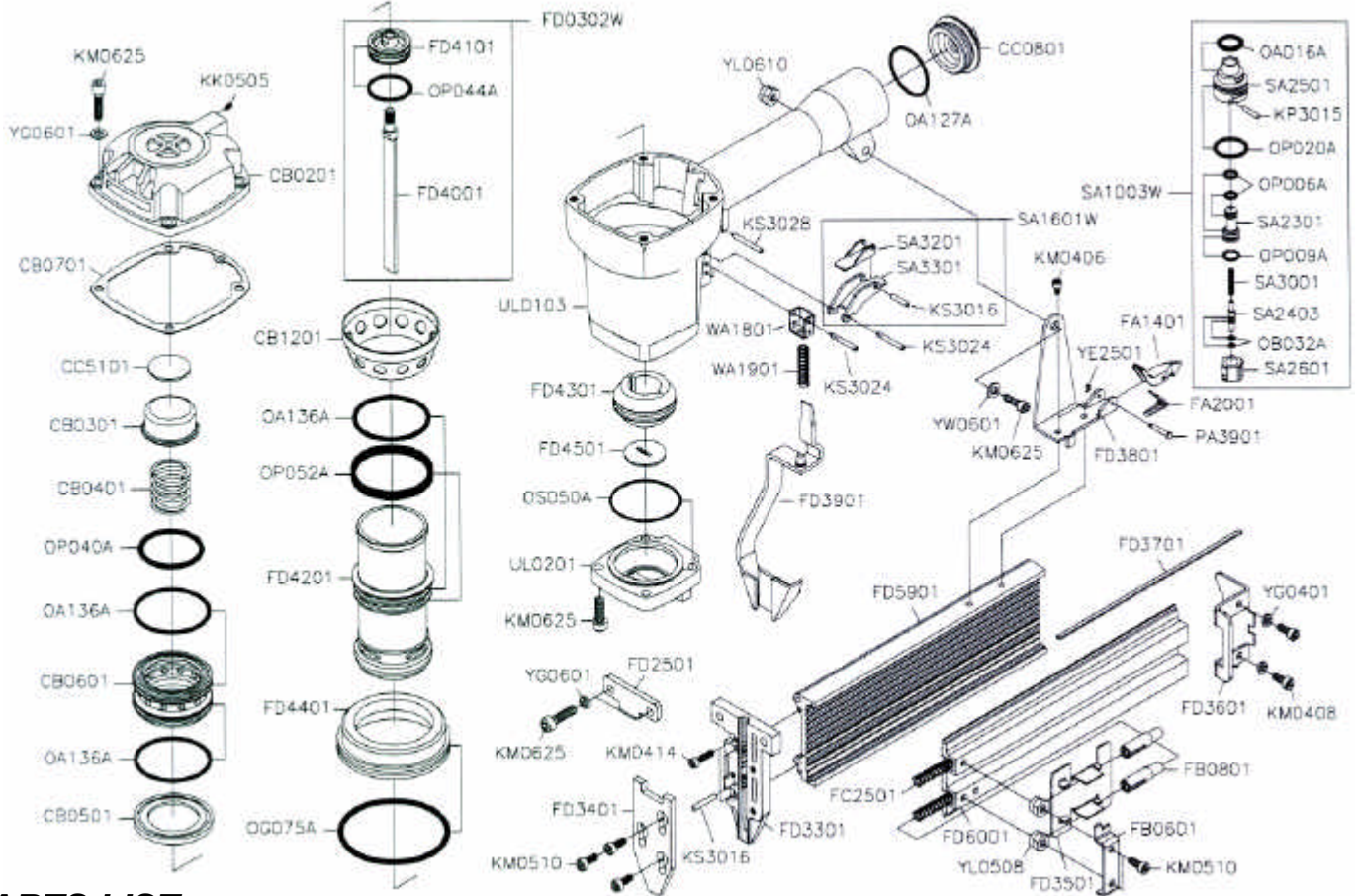

PARTS LIST

◆ : Consuming Part

Item No.	Part No.	Description	Qty.	Item No.	Part No.	Description	Qty.	Item No.	Part No.	Description	Qty.
1	CB0201	Cylinder Cap	1	26	FD4201	Cylinder	1	51	OP044A	O-Ring P44	1
2	CB0301	Piston Stop	1	27	FD4301	Bumper	1	52	OP052A	O-Ring P52	1
3	CB0401	Compression Spring	1	28	FD4401	Cylinder Ring	1	53	OS050A	O-Ring S-50	1
4	CB0501	Head Valve Seal	1	29	FD4501	Nozzle	1	54	PA3901	Pin	1
5	CB0601	Head Valve Piston	1	30	FD5901	Magazine Seat	1	55	SA1003W	Restrictive Trigger Assy.	1
6	CB0701	Cap Seal	1	31	FD6001	Magazine Cap	1	56	SA1601W	Trigger Assy.	1
7	CB1201	Collar	1	32	KK0505	Hex.Soc.Set Screw M5x0.8-5L	1	57	SA2301	Pilot Valve	1
8	CC0801	End Cap	1	33	KM0406	Hex.Soc.Hd.Bolt M4x0.7-6L	2	58	SA2403	Trigger Valve Stem	1
9	CC5101	Piston Stop Spacer	1	34	KM0408	Hex.Soc.Hd.Bolt M4x0.7-8L	2	59	SA2501	Trigger Valve Seat	1
10	FA1401	Latch	1	35	KM0414	Hex.Soc.Hd.Bolt M4x0.7-14L	2	60	SA2601	Trigger Valve Seat	1
11	FA2001	Spring	1	36	KM0510	Hex.Soc.Hd.Bolt M5x0.8-10L	5	61	SA3001	Compression Spring	1
12	FB0601	Magazine Retainer	1	37	KM0625	Hex.Soc.Hd.Bolt M6x1.0-25L	11	62	SA3201	Contact Lever	1
13	FB0801	Pusher Pin	2	38	KP3015	Parallel Pin ø3x15L	2	63	SA3301	Trigger	1
14	FC2501	Pusher Spring	2	39	KS3016	Spring Pin ø3-16L	3	64	UL0103	Body	1
15	FD0302W	Driver Assy.	1	40	KS3024	Spring Pin ø3-24L	3	65	UL0201	Side Plate(L.H.)	1
16	FD2501	Cover Plate(A)	1	41	KS3028	Spring Pin ø3-28L	1	66	WA1801	Safety Guide	1
17	FD3301	Guide Plate	1	42	OA016A	O-Ring ARP568-016	1	67	WA1901	Compression Spring	1
18	FD3401	Cover Plate(B)	1	43	OA127A	O-Ring ARP568-127	1	68	YE2501	E-Ring ø2.5	1
19	FD3501	Pusher	1	44	OA136A	O-Ring ARP568-136	3	69	YG0401	Spring Washer ø4	2
20	FD3601	Stop Plate	1	45	OB032A	O-Ring 2.5x1.4	2	70	YG0601	Spring Washer ø6	6
21	FD3701	Bar	1	46	OG075A	O-Ring G75	1	71	YL0508	Lock Nut M5x0.8	2
22	FD3801	Support	1	47	OP006A	O-Ring P6	2	72	YL0610	Lock Nut M6x1.0	1
23	FD3901	Safety	1	48	OP009A	O-Ring P9	1	73	YW0601	Flat Washer ø6	1
24	FD4001	Driver	1	49	OP020A	O-Ring P20	1				
25	FD4101	Main Piston	1	50	OP040A	O-Ring P40	1				