

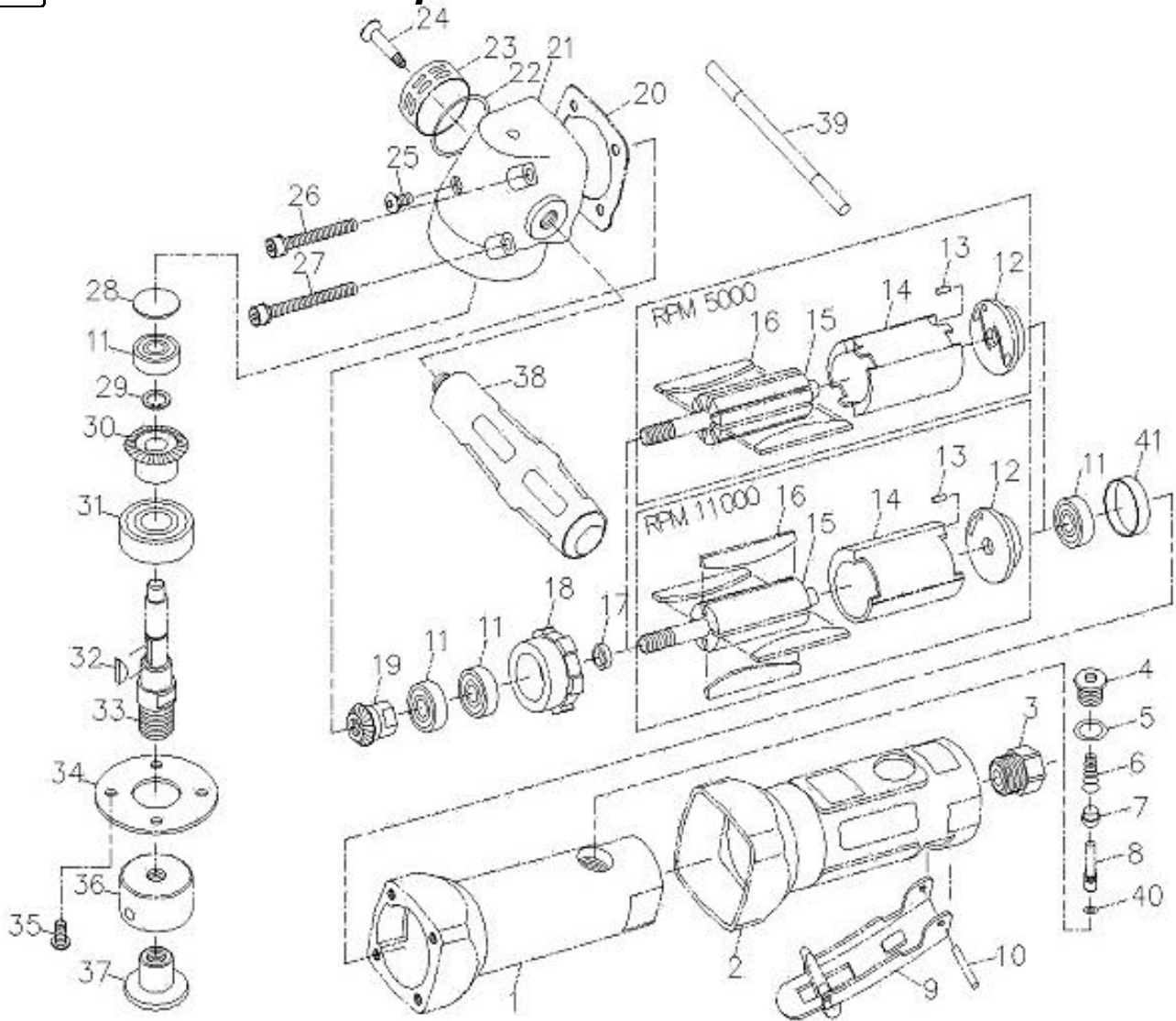

GISON Pneumatic Tools

GP-823S 100 Depressed Disc Sander



PARTS LIST

✳ : Consuming Part

No.	Part No.	Description	Qty.	No.	Part No.	Description	Qty.
1	823S01	Housing	1	20	823S20	Packing	1
2	823S02	Rubber	1	21	823S21	Angle Housing	1
3	823S03	Air Inlet	1	22	823S22	O-Ring	1
4	823S04	Screw	1	23	823S23	Exhaust Sleeve	1
5	823S05	O-Ring	1	24	823S24	Screw	1
6	823S06	Spring	1	25	823S25	Screw	1
7	823S07	Valve Stem Bushing	1	26	823S26	Screw (M5x45L)	2
8	823S08	Valve Stem	1	27	823S27	Screw (M5x55L)	2
9	823S09	Lever	1	28	823S28	Spacer	1
10	823S10	Spring Pin	1	29	823S29	Retaining Ring	1
11	823S11	Bearing	4	30	823S30	Bevel Gear	1
12	823S12-1	Rear Plate (RPM 11000)	1	31	823S31	Bearing	1
	823S12-1.1	Rear Plate (RPM 5000)		32	823S32	Key	1
13	823S13	Pin (Steel Ball)	1	33	823S33	Shaft	1
14	823S14	Cylinder (RPM 11000)	1	34	823S34	Face Plate	1
	823S14-1	Cylinder (RPM 5000)		35	823S35	Screw	4
15	823S15	Rotor (RPM 11000)	1	36	823S36	Sanding Adapter	1
	823S15-1	Rotor (RPM 5000)		37	823S37	Adaptor Lock Down	1
16	823S16	Rotor Blade (RPM 11000)	4	38	823S38	Handle	1
	823S16-1	Rotor Blade (RPM 5000)	8	39	823S39	Holdint Tool	1
17	823S17	Bearing Spacer	1	40	823S40	O-Ring	1
18	823S18	Front Plate	1	41	823S41	Shroud	1
19	823S19	Bevel Gear	1				