

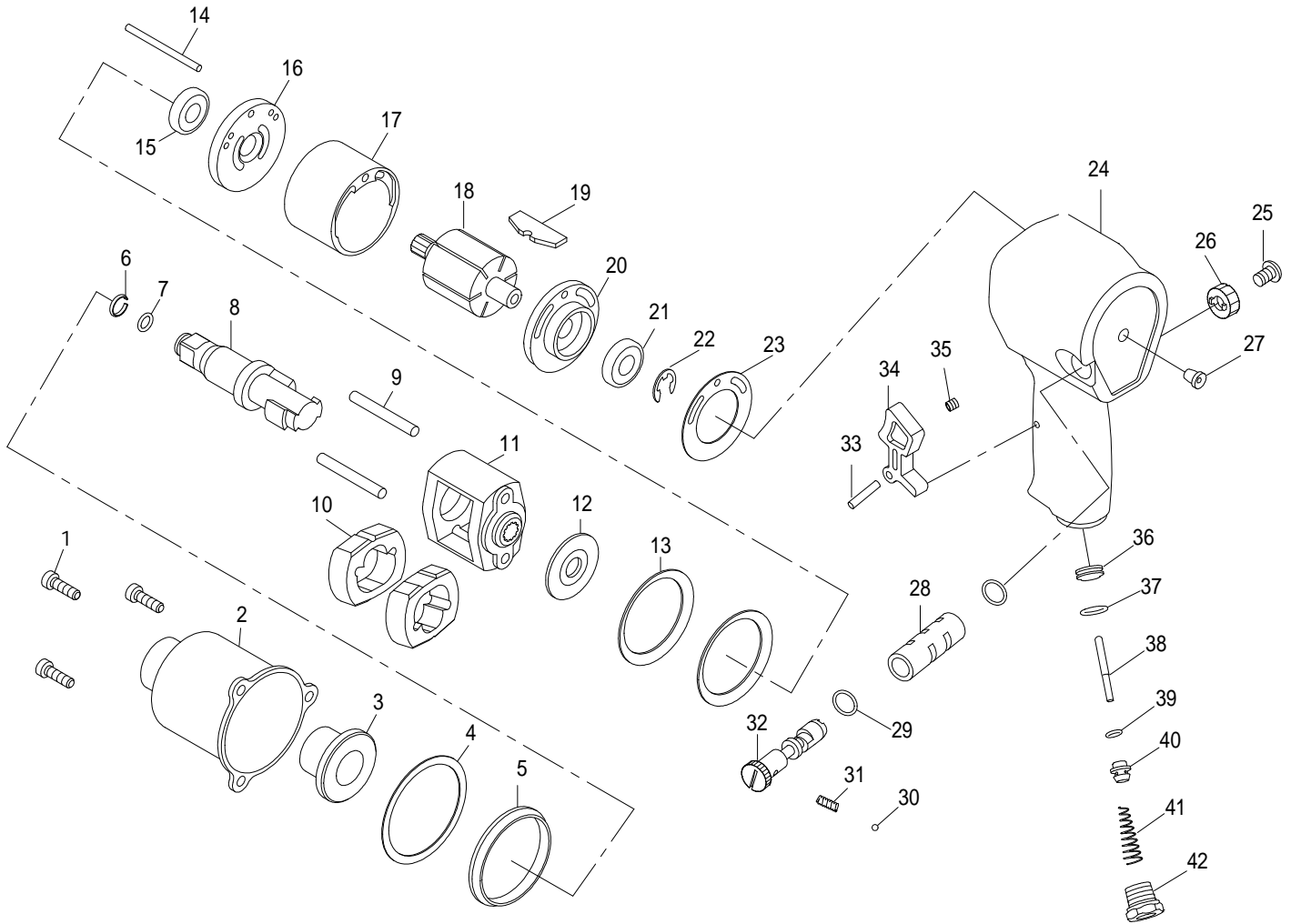

GISON Pneumatic Tools

GW-19D 1/2" Air Impact Wrench



PARTS LIST

✳ : Consuming Part

Item No.	Part No.	Description	Qty.	Item No.	Part No.	Description	Qty.
1	19D001	Screw	3	22	19D022	E-Ring	1
2	19D002	Clutch Housing	1	23	19D023	End Plate Gasket	1
3	19D003	Anvil Bushing	1	24	19D024	Motor Housing	1
4	19D004	Front Gasket	1	25	19D025	Screw	1
5	19D005	Clutch Housing Pilot	1	26	19D026	Reverse Valve Knob	1
6	19D006	Anvil Collar	1	27	19D027	Grease Fitting	1
7	19D007	O-Ring	1	28	19D028	Valve Sleeve	1
8	19D008	Anvil	1	29	19D029	O-Ring	1
9	19D009	Hammer Pin	2	30	19D030	Steel Ball	2
10	19D010	Hammer Dog	2	31	19D031	Spring	1
11	19D011	Hammer Cage	1	32	19D032	Reverse Valve	1
12	19D012	Hammer Washer	1	33	19D033	Steel Pin	1
13	19D013	Disc Spring	2	34	19D034	Trigger	1
14	19D014	Cylinder Pin	1	35	19D035	Screw	1
15	19D015	Ball Bearing	1	36	19D036	Throttle Bushing	1
16	19D016	Front End Plate	1	37	19D037	O-Ring	1
17	19D017	Cylinder	1	38	19D038	Valve Tappet	1
18	19D018	Rotor	1	39	19D039	O-Ring	1
19	19D019	Rotor Balde	6	40	19D040	Valve Stem	1
20	19D020	Rear End Plate	1	41	19D041	Spring	1
21	19D022	Ball Bearing	1	42	19D042	Hose Fitting	1