

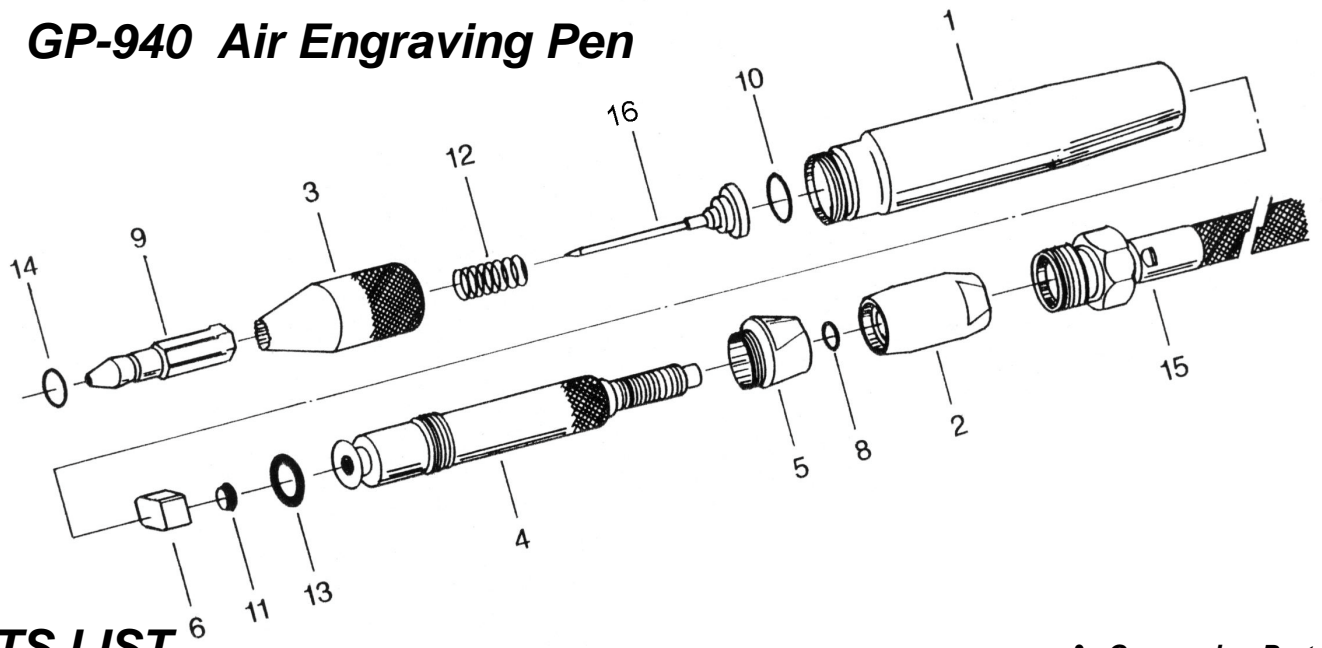

GISON Pneumatic Tools

GP-940 Air Engraving Pen



PARTS LIST

✿ :Consuming Part

Item No.	Part No.	Description	Qty.	Item No.	Part No.	Description	Qty.
1	940001	Body	1	11	940011	Oil Seal	1
2	940002	Adjustment Nut	1	✿ 12	940012	Spring	1
3	940003	Front Plate	1	✿ 13	940013	O-Ring	1
4	940004	Throttle Valve	1	✿ 14	940014	O-Ring	1
5	940005	Ring Nut	1	15	940015	Air Hose	1
6	940006	Valve Seat	1	16	940016-1	Sleeve for Thin Point	1
✿ 8	940008	O-Ring	1		940016-2	Sleeve for Medium Point	1
9	940009	Bush	1		940016-3	Sleeve for Large Point	1
✿ 10	940010	O-Ring	1				

2008/6/23

Features: The Air Engraving Stylus is used to write on hard steel, metal, glass, stones, ceramic, plastics etc. also useful for deburring, to reshape the cut on the screwhead or broken bolts to ease removal, and naturally, to personalise tools and other equipment in the workshop.

- To obtain the best marking, hold the pen near the front at sharp angle.

Maintenance:

- Turn the **valve (4)** so to have maximum power at the point. The valve can also be adjusted to reduce the impact force, eg. to work on softer material or to make thin markings. If the pen does not start hit lightly the point against a surface, this happen when the valve is not opened enough.
- To remove the **bush (9)** push from the **front part (3)** towards the inside. Insert by pushing a new bush until the flange lays against the side of the hole at the front end.
- To substitute the point unscrew the **front end (3)** holding the **body (1)** in a vice. Take out the worm point and replace it with a new one.
- Clean the pen thoroughly after disassembling and assembling. Use pure clean air, as free of dust and humidity as ever possible.

Lubricator:

- Lubricate the pen daily, or every time it is used. Use very fluid mineral oil, free from acids and carbon or gummy residues. The recommended viscosity is 1.7 - 3.3 E/50 . The lubrication can be done by automatic lubricators.

Hose Fitting:

- Before hoses are connected to the tool, blow them clean with a blow gun. If the pressure is too low the pen will not work satisfactorily.